

# R-312/200

HYDRAULIC ROTARY RIG





SOILMEC

R-312/200

# R-312/200

## HYDRAULIC ROTARY RIG

### A new model

After the success of the R-312 HD Soilmec introduces the new model R-312/200 performing:

- **bored piles with dry drilling or bentonite mud**
- **continuous flight auger piles (CFA)**

The main features of the R-312/200 are the following:

- new powerful rotary
- high speed drilling
- easy transport: it can be transported with rotary and kelly bar installed
- compliance with the machine laws for safety standards
- total reduction of rig up time, about 20 minutes from arrival to the job site
- easy to use and handle
- low operating costs
- wide range of accessories (depthmeter, inclinometer, air conditioning, free fall winch)

### Large diameter bored pile

Max pile diameter	mm	1500
Max pile depth	m	48 (with 5x11 kelly bar)
	m	38,5 (with 4x11 kelly bar)
Max nominal torque	kNm	130
Max drilling speed	rpm	42
Spin off speed	rpm	153
Main winch nominal line pull	kN	133
Auxiliary winch nominal line pull	kN	56
Engine	type	CUMMINS QSB5.9
Power	BHP	200 @ 2200 rpm
Crowd system	kN	123.7 / 101.8
Operating weight	tons	35
Transport weight (c/w kelly bar)	tons	34

The nominal values are referred to 100% total efficiency.

### Continuous Flight Auger (CFA)

Max pile diameter	mm	750
Max pile depth	m	13-6
Max nominal extraction force	kN	380
Transport weight	tons	31

### Friction kelly bar – Ø 355 mm

elements no	length m	depth m	weight tonn	height m
4x	6,0	19,0	2,4	5,0
4x	7,5	25,0	2,9	5,0
4x	9,0	32,0	3,3	5,0
4x	11,0	39,0	3,9	4,6
5x	9,0	40,0	4,3	5,0
5x	11,0	48,0	5,1	4,6

### Mechanical locking kelly bar – Ø 355 mm

elements no	length m	depth m	weight tonn	height m
4x	7,5	25,0	2,9	5,0
4x	9,0	34,0	3,3	5,0
4x	11,0	38,0	3,9	4,6

Standard dimension of tool connection is 130x130 mm / H=kelly stub height from ground level

- 1 - **Undercarriage** with expandable tracks from 2.5 to 3.7 m by means of hydraulic cylinders
- 2 - **Turret** c/w CUMMINS 6BTA55.9-C200 diesel engine and sound proofed canopy, mounted on a 360° slew ring
- 3 - **Winch** assembly
- 4 - **Parallelogram system** allowing working radius adjustment always maintaining the mast in vertical position. C/w electronic device for automatic stop
- 5 - **Self-erecting mast** composed by an intermediate element 11.9 m long and a top element 3.5 m long. The max torque can be applied all over the mast length
- 6 - **Sheave cathead**
- 7 - **Crowd system** by means of 3.5 m hydraulic cylinder
- 8 - **Rotary head** with 3 drilling speeds and one high spin off speed. The max torque is obtained for each drilling speed
- 9 - **Telescopic kelly bar** with guide to mast available with friction or mechanical locking type



Inside cabin view



6

5

7

8

9

4

3

2

1

# R-312/200

## LARGE DIAMETER BORED PILE

### Working Condition

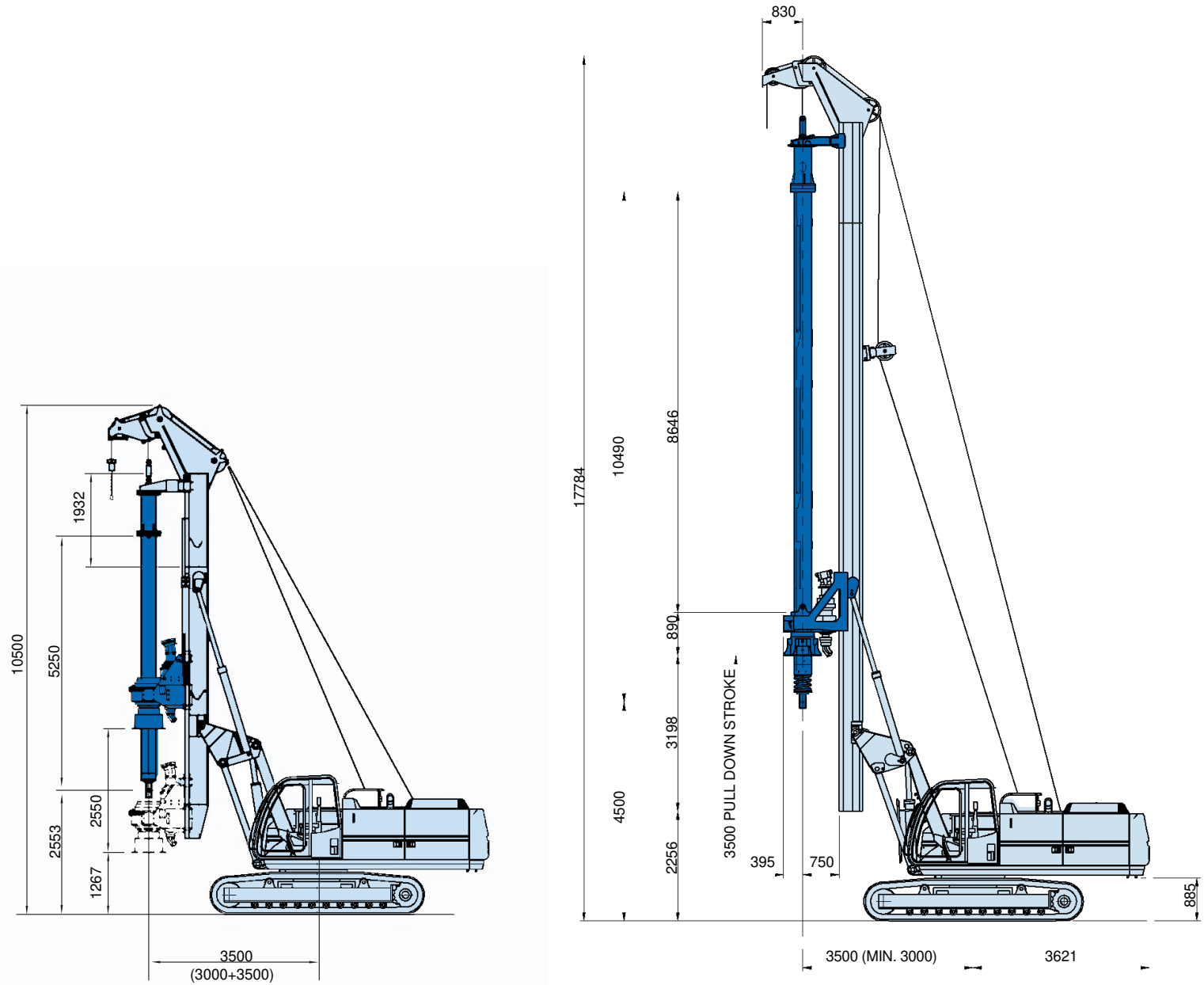

Low overhead version

Standard version

### Transport Condition

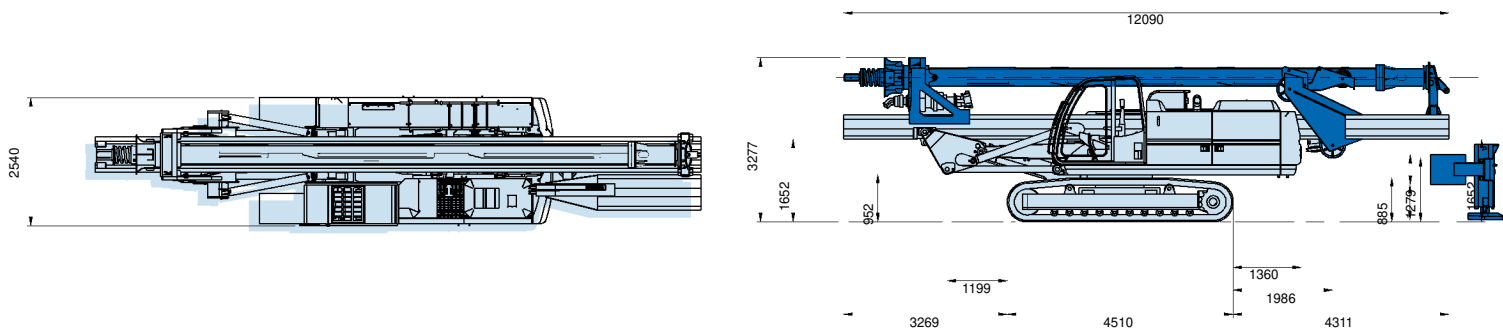

# R-312/200

## CONTINUOUS FLIGHT AUGER

### Working Condition

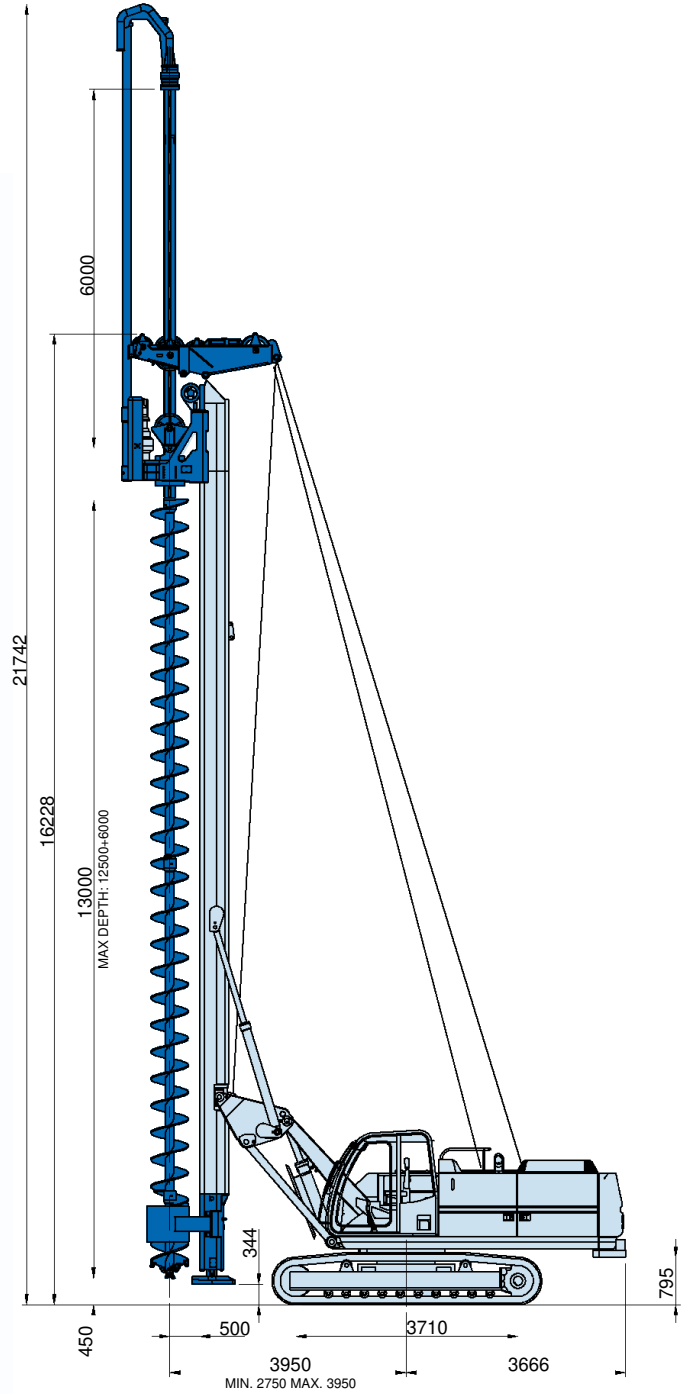
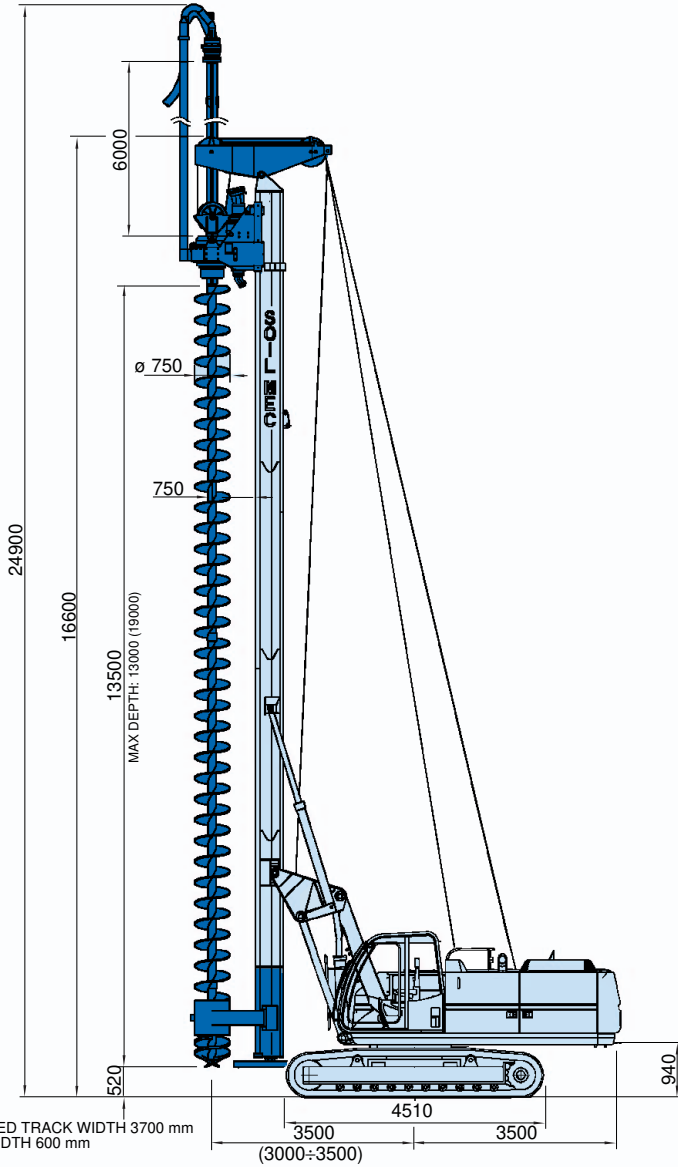

### CFA standard version

### CFA 360° version

### Transport Condition

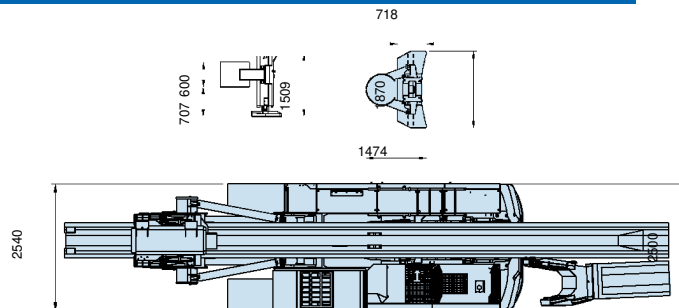
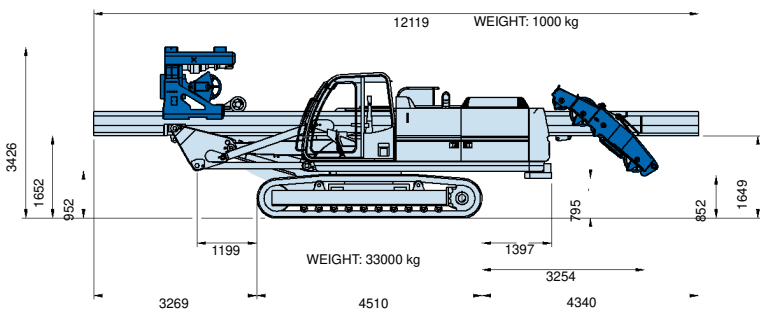



SOILMEC distributes machinery and structures all over the world, supported by SOILMEC subsidiary companies and representative offices as:

**SOILMEC LTD** - U.K.

**SOILMEC MISR S.A.E. Co.** - Egypt

**SOILMEC (H.K.) Limited** - Hong Kong

**SOILMEC JAPAN CO LTD** - Japan

**SOILMEC MALAYSIA** - Malaysia

**SOILMEC S.P.A. - Beijing Repr. Office** - P.R. China

**SOILMEC FAR EAST PTE.LTD** - Singapore

**SOILMEC EMIRATES** - U.A.E.

**SOILMEC GULF** - U.A.E.

## CERTIFIED QUALITY SYSTEM

In 1990 Soilmec was awarded the certification of its own Quality System to ISO 9001/UNI 29001 series standards.



**SOILMEC S.p.A.**

**Ground Engineering Equipment**

5819, via Dismano

47023 Cesena (FC) - Italy

tel. +39-0547-319111

fax +39-0547-318548

[http:// www.soilmec.it](http://www.soilmec.it)

e-mail: [soilmec@soilmec.it](mailto:soilmec@soilmec.it)